

Prepared ERU/XMR GREGORY WHITE		Checked G.W.	Document no. XM-92329		
Approved	Checked	Date 11/13/92	Rev A	File reference E:\WPDOC	

**I. DESCRIPTION**

The CCRS removes one transmitter (CC) from the transmitter combiner and replaces it with a designated transmitter (CCRS). The designated transmitter is switched into the signal path of the one removed. The command signal for switch-over is initiated by the station supervisory circuit. The CCRS has two modes: normal and alternate. In the normal mode, coaxial switches connect the CC input to the CH1 output and the CCR input to the CH2 output. In the alternate mode, the CC and CH2 are opened and the CCR input is switched to the CH1 output. When the DC power is first applied the unit will be in normal mode. The switch-over to a different mode is initiated by a high to low transitions of the input signals CCH1 and CCH2. The CCH1 will initiate a normal mode and the CCH2 will initiate the alternate mode. The LED's on the front panel indicates the mode of the CCRS.

**II. SPECIFICATIONS:**

Frequency Range	870 - 865 MHZ
Nominal impedance	50 ohms unbalanced
Max. VSWR, input & output	1.3:1
Insertion Loss	
normal mode	.4 dB Max.
alternate mode (CCR)	.7 dB Max.
(CC)	30 dB Min.
Max. input power	200 watts
Command signals	
High	12 - 15 volts
Low	0 - .5 volts
Supply Voltage	26 volts

**III. INSTALLATION:**

- A. Mount the CCRS unit in the designated rack space.
- B. Connect cables CC and CCR inputs to the transmitters.
  
- C. Connect cables from the CH1 and CH2 outputs to the inputs of the transmitter combiner.
- D. Wire-in power supply and command signals CCH1 and CCH2.

Prepared <b>ERU/XMR GREGORY WHITE</b>	Path	Document no. <b>XM-92329</b>		
Approved	Checked	Date <b>11/13/92</b>	Rev <b>A</b>	File reference <b>E:\WPDOC</b>

#### **IV. TESTING**

Verify that the following details have been performed prior to testing the CCRS module.

Connect PMU detector output to a 50 ohm dummy load. Verify that CCRS installation has been performed correctly. Make sure that all RF cables have been connected and combiner has been aligned. Green LED (PWR) and yellow LED (CC) should be illuminated when supply voltage is connected.

Connect service computer to the primary control channel. From the service computer menu, select the channel number assigned to the control channel and key the transmitter with 0dB attenuation. Observe forward power reading on PMU. Record reading on test record. Turn transmitter off.

Connect service computer to alternate control channel. Select channel number assigned to primary control channel. Key the transmitter with 0dB attenuation and activate CCRS to alternate mode from the service computer menu. CCR LED should be illuminated. Observe forward power reading on PMU to verify that RF power from CCR has been routed to CC combiner cavity. Record reading in test record. Turn transmitter off.

**NOTE:** If forward power reading is decreased by more than .3db in CCR mode, re-check transmitter output power and combiner alignment.

Disconnect supply voltage from CCRS. When supply voltage is re-applied, the CCRS will revert back to normal mode regardless of its state prior to the supply interruption. Verify that PWR and CC LED's are illuminated when voltage is re-applied.

#### **V. MAINTENANCE:**

Periodic maintenance is not a requirement for this device.

REV	PWO #	DATE	DFTR	DESCRIPTION
A		02-06-92	B.S.	INITIAL RELEASE
B		08-21-92	T.C.	REVISED DRAWING

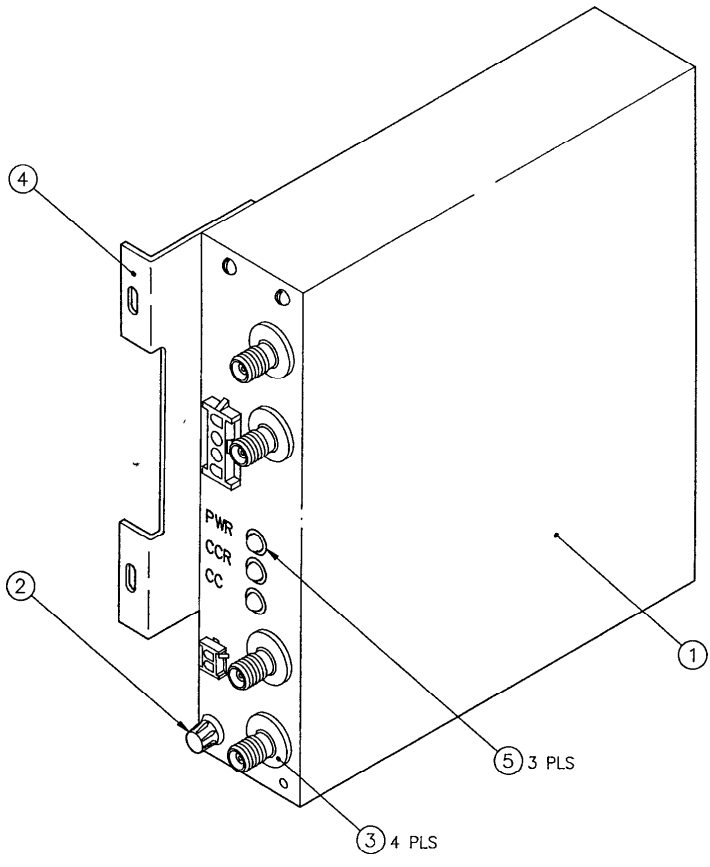

**NOTES:**

- ① RSA CCRS
- ② FUSE RETAINER
- ③ FEMALE "N" CONNECTOR
- ④ MOUNTING BRACKET
- ⑤ LED INDICATORS

TITLE <b>RBS 500 HP CCRS</b>		<b>ERICSSON</b> 	
PROJECT TYPICAL		Ericsson Radio Systems Inc.	
SITE NO./NAME TYPICAL		<small>THIS DRAWING IS THE PROPERTY OF ERICSSON RADIO SYSTEMS INC. IT IS TO BE USED ONLY FOR THE PROJECT AND SITE SPECIFICALLY IDENTIFIED HEREON. IT IS NOT TO BE REPRODUCED, COPIED, EITHER WHOLLY OR IN PART, OR TRANSMITTED IN ANY FORM OR BY ANY MEANS, ELECTRONIC OR MECHANICAL, INCLUDING PHOTOCOPYING, RECORDING, OR BY ANY INFORMATION STORAGE AND RETRIEVAL SYSTEM, WITHOUT THE WRITTEN PERMISSION OF ERICSSON RADIO SYSTEMS INC.</small>	
DRAFTER B. SORRELLS 06 FEB 92	DWG. NO. <b>C 1533-IPA-1113567</b>	B	
CHECKER <i>Gregory White</i> 09/21/92	DWG. SIZE SCALE NONE	SHEET 1 OF 1	REV
APPROVAL			