

Prepared ERU/XMR GREGORY WHITE	Path <i>G.W.</i>	Document no. XM-92330		
Approved	Checked	Date 11/13/92	Rev A	File reference E:\WPDOC

I. DESCRIPTION

The RBS 500 HP PMU consists of an RF coupler and a detecting and control unit. The PMU monitors the forward and reverse through the coupler and calculates the VSWR. The signal level is attenuated enough so that the detector diode is in the square law region. The sum of the powers will be truer than detectors that do not operate in the square law region.

The directional coupler is a 40 dB coupler. The maximum average power the coupler can tolerate is 1000 watts. The direction of the signal coupled is labeled on each side of the coupler. A set of two 3.5 foot RG 142 cables is incorporated into the PMU which connects the coupler to the front panel of the PMU. The coupler serial number should match the PMU's serial number. The PMU was calibrated with that coupler, and they should be used together.

The VSWR display range is 1.00 to 9.99. If the VSWR is over 9.99:1, a value of 9.99 will be displayed until the VSWR drops below 9.99. The power display range for the forward power is 0 to 999 watts. The power range for the reverse power is 0 to 99 watts. For power levels under 50 watts, the power indicated is accurate to 1/10 of a watt. If a power level is over the display range, the indication will show maximum reading: 999 watts for the forward power and 99 watts for the reverse power respectively. When the forward power is less than 0.3. watts, the VSWR will disable and clear. This keeps the PMU from triggering an alarm condition when the transmitters are not keyed. The VSWR display will indicate a series of dashes (-.-) when the VSWR is disabled. The VSWR, forward and reverse power is selected for display by a three position toggle switch on the front panel labeled DISP SEL.

The alarm is factory set to 2:1 VSWR. The alarm will activate when the VSWR is greater than or equal to 2.00. The output of the VSWR alarm is an open collector transistor. Under normal conditions, the output transistor will be on (low impedance between the + and - alarm terminals). Under an alarm condition, the output transistor will be turned off (high impedance between the + and - alarm terminals). When the output transistor is on with 10 mA current, the voltage across the alarm leads is less than 0.40 volts.

II. SPECIFICATIONS

Frequency	869.0 - 891.5 MHz
Power Range (FWD)	0.5 - 999 Watts
Power Range (REV)	0.5 - 99 Watts
Accuracy	+/- 1 dB

Prepared	Path	Document no.		
ERU/XMR GREGORY WHITE		XM-92330		
Approved	Checked	Date	Rev	File reference
		11/13/92	A	E:\WPDOC

Max input power (Coupler FWD)	1000 Watts
Max input power (Coupler REV)	100 Watts
Max input power (PMU FWD)	+20 dBm
Max input power (PMU REV)	+10 dBm
Power (DC)	4 Watts
Supply Voltage	19-33 Volts
RF Coupler	40 dB +/- 0.5 dB

III. INSTALLATION

Connect the power supply and alarm circuits. The pin connections are labeled on the front panel. Connect cables from the PMU to the TNC connectors on the coupler, making sure the FWD cable is connected to the connector on the coupler labeled FORWARD. The reverse cable goes to the connector on the coupler labeled REVERSE. Make sure that the serial numbers on both the coupler and the PMU are identical.

IV. TESTING

Turn the power on and allow it a few minutes for the temperature to stabilize. Connect a suitable dummy load to the antenna connector on the coupler. Set the selection switch to ANT FWD and apply known power to the load. The PMU reading should be consistent with the known power. Remove the dummy load from the coupler and leave the antenna connector open. Select ANT REV with the display selection switch. The reading should be consistent with the known power. Leave the antenna connector open only long enough to ascertain that the reflected power reading is correct.

Harness together two 50 ohm dummy loads using a tee connector and equal length cables and connect it to the antenna connector of the coupler. Select the VSWR with the display selection switch. Reflected power should be approximately 10% of the forward power and the display should indicate 2.00. The alarm indicator lamp should light the alarm output transistor should turn on. If the alarm light does not illuminate, chances are that the VSWR is not quite 2.00. Decrease the power and disconnect the dummy load. A high VSWR will be created which will trigger the 2.00 alarm condition.

If a matching network and network analyzer is available, the VSWR of the load can be set. Connect the matching network to the load and using the network analyzer adjust the matching network to produce a 14dB return loss. Connect the matching network to the antenna port of the coupler and the VSWR display should read 1.50. With the network analyzer, adjust matching network to achieve a 9.5dB return loss.

Prepared	Path	Document no.		
ERU/XMR GREGORY WHITE		XM-92330		
Approved	checked	Date	rev	File reference
		11/13/92	A	E:\WPDOC

Connect it to the coupler and the VSWR display should read 2.00.

V. MAINTENANCE

Period maintenance is not a requirement for this device.

REV	PWO #	DATE	DFT.	DE.	ION
A		02-12-92	B.S		INITIAL RELEASE
B		08-21-92	T.C		REVISED DRAWING TITLE

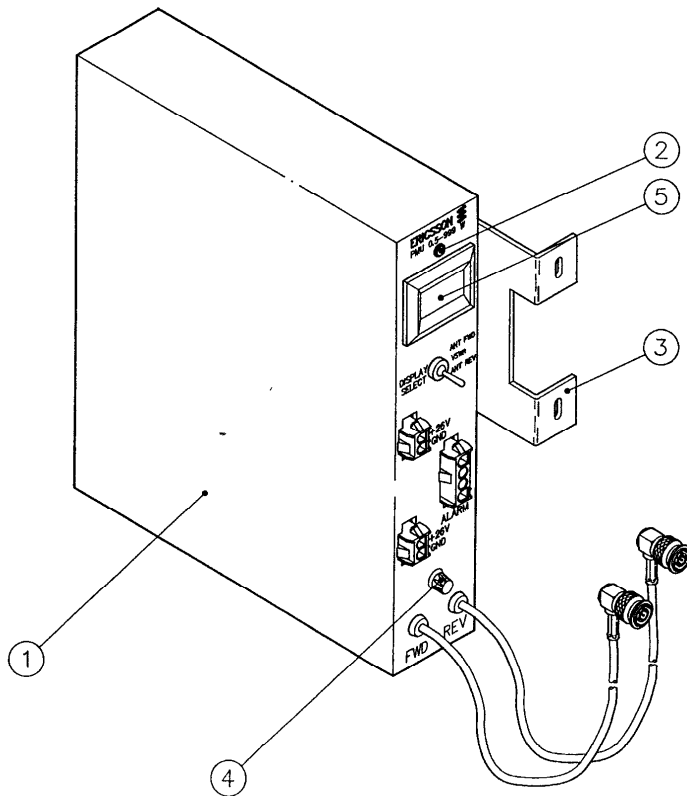

NOTES:

- ① RSA PMU
- ② ALARM LED (RED)
- ③ MOUNTING BRACKET
- ④ FUSE RETAINER
- ⑤ DISPLAY

TITLE		RBS 500 HP PMU			
PROJECT		TYPICAL		Ericsson Radio Systems Inc.	
SITE NO./NAME		TYPICAL		<small>This document and its information constitute a confidential communication of Ericsson Radio Systems Inc. and are not to be disclosed, copied, reproduced, or used in any way without the prior written permission of Ericsson Radio Systems Inc. in writing. All rights are reserved. © 1992 Ericsson Radio Systems Inc. All rights reserved.</small>	
DRAFTER	B. SORRELLS	06 FEB 92	DWG. NO.	1533-IPA-1113566	B
CHECKER	<i>Gregory White</i>	<i>07/21/92</i>	SCALE	NONE	SHEET 1 OF 1
APPROVAL			REV		