

MOB-IP-SIM: A Lab Test Solution for cdma2000 Mobile IP Enabled Devices

White Paper

February 2003

***S*oftware
*C*oncepts
*I*nc.**

182-104 Wind Chime Court
Raleigh, NC 27615
919.846.5583
www.softwareconceptsinc.net

Table of Contents

Introduction	3
What is Mobile IP?	3
Simple IP	5
Commercial Mobile IP Networks	6
Mobile IP Lab Test Environment	7
Simulator Challenges	7
Simulator Requirements	8
MOB-IP-SIM Solution	8
System Overview	9
Hardware	9
Software	10
Supported Features	10
Configuration	10
Test Automation	11
Conclusion	11

Introduction

Mobile IP has become an everyday term in the field of wireless internet technology. This technology provides a means for wireless devices to maintain a static Internet Protocol (IP) address when moving from one internet connection to another where the device's local IP address is changing from time to time. Systems that include this new technology are being deployed every day, but few test systems are currently available to verify wireless device performance and behavior in a lab environment.

This paper introduces the **cdma2000** wireless Mobile IP data network, then proposes requirements for a test system, and concludes with a test solution specifically designed for cdma2000 handsets and other Mobile IP enabled devices. The test system is composed of an existing cdma2000 base station emulator and Software Concept's MOB-IP-SIM network simulator. The single unit network simulator provides a complete Mobile IP test solution for cdma2000 handsets and other devices that use Mobile IP protocols for packet data communications. The MOB-IP-SIM system can be configured to simulate a complete IP mobility network, or it can be configured to simulate a partial network while acting as an interface to other network components using its built-in LAN connection.

What is Mobile IP?

The internet standard for Mobile IP can be found in the IETF document [RFC-2002 \(IP Mobility Support\)](#) or the later revision document [RFC-3344](#). The abstract found in RFC-2002 provides a good technical introduction to the Mobile IP concept (ref: www.ietf.org):

"This document specifies protocol enhancements that allow transparent routing of IP datagrams to mobile nodes in the Internet. Each mobile node is always identified by its home address, regardless of its current point of attachment to the Internet. While situated away from its home, a mobile node is also associated with a care-of address, which provides information about its current point of attachment to the Internet. The protocol provides for registering the care-of address with a home agent. The home agent sends datagrams destined for the mobile node through a tunnel to the care of address. After arriving at the end of the tunnel, each datagram is then delivered to the mobile node."

Fig. 1 shows this data flow in a typical wireless Mobile IP system.

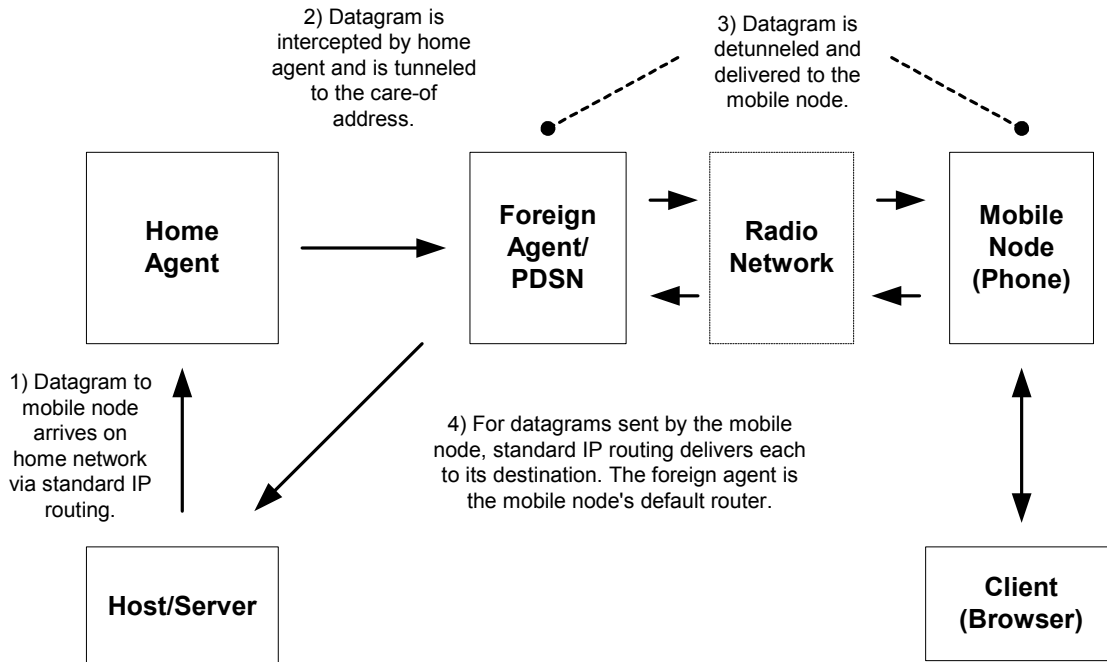

Fig. 1, Mobile IP Network Data Flow

Most systems use a more limited standard to reference portions of the RFC-2002 document. The TIA/IS-835 cdma2000 Wireless IP Network Standard defines the cdma2000 specific implementation of **Mobile IP** for the test system defined in this paper.

Simple IP

IS-835 also specifies **Simple IP**, which was referred to as "Packet Data" by previous standards like IS-707. Fig. 2 shows a typical Simple IP data flow. Comparing this to the Mobile IP data flow in Fig. 1, one can see that Simple IP has no provision to allow PDSN changes during a given Host/Client session. Simple IP, as defined in IS-835, includes some PDSN to PDSN protocol enhancements to provide better "mobility" performance over previous standards, but still remains limited compared to Mobile IP. Simple IP will continue to be used in cdma2000 systems for backward compatibility; however, it is not the primary subject of this paper and will only be discussed as required beyond this point.

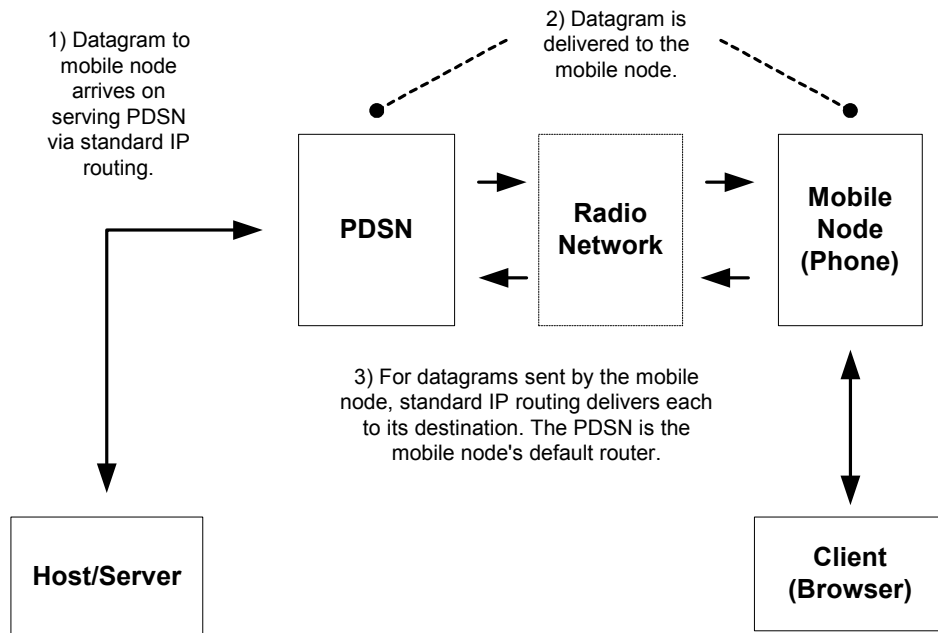

Fig. 2, Simple IP Network Data Flow

Commercial Mobile IP Networks

Commercial cdma2000 networks contain many components from a variety of vendors. These components work together to provide large scaled services and features that generate revenue for the carrier. Fig. 3 shows the key elements required to support data services on this type of system.

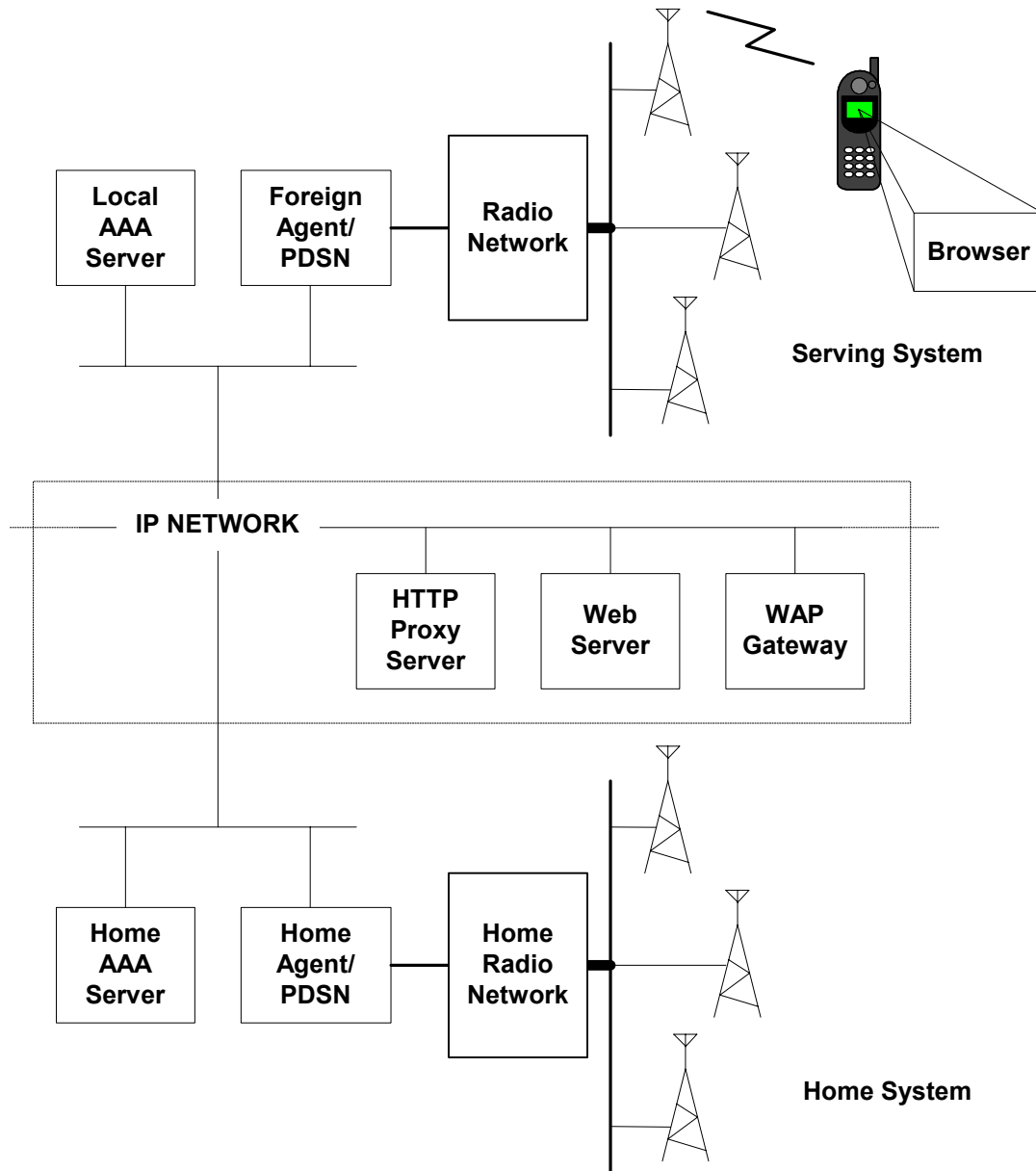

Fig. 3, Commercial Mobile IP Data System

Even this rudimentary block diagram indicates a complicated system that requires many internet components just to provide data services. A more

manageable system is obviously needed for testing mobile devices in a controlled environment.

Mobile IP Lab Test Environment

Simulating a commercial network infrastructure is a challenge. Many options and system variation possibilities are contained in the RFC and TIA documents, so one can expect to experience some level of difficulty when setting up a lab environment to match a commercial system configuration. In any event, a flexible test system will be needed to be successful.

Lab test system capabilities for wireless devices vary significantly. In most cases, test sets are limited to predefined call setup sequences and allow the user to invoke few, if any, fault conditions. Improved data test systems are obviously needed. A simplified version of the commercial system can provide the needed functionality for improved Mobile IP device testing. Fig. 4 shows how the elements of this proposed test system could be assembled.

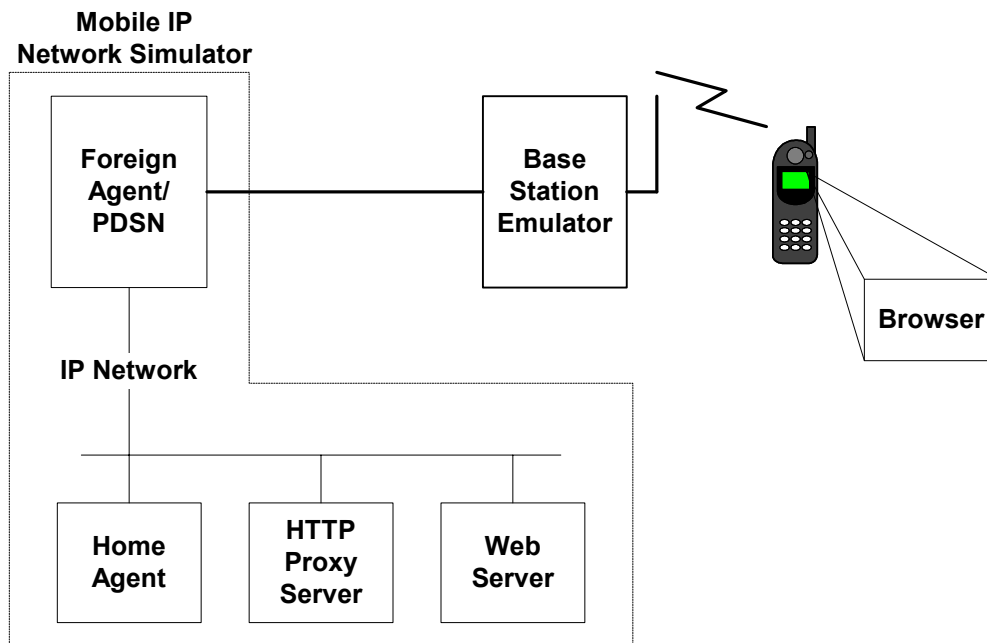

Fig. 4, Mobile IP Test Environment

Simulator Challenges

A commercial **cdma2000** system with Mobile IP support contains many items such as the Radio Network, Home Agent, Foreign Agent, PDSN, AAA Server, etc.(see Fig. 3). These components are not designed for use in product development labs and are not feasible for this environment because of cost and

lack of error simulation. Fortunately, the lab environment needs to emulate only the connection points that are exposed to the Mobile IP device. Other elements of the system can be simulated or even omitted in such an environment.

Another issue with building a test system for Mobile IP devices is the learning curve required to understand the details of the various components and their interaction with each other. A mobile IP simulator should contain all the necessary IP components in order to reduce the test system complexity and to make it easy to configure. If additional test elements are needed, it should also be possible to add them externally using a LAN connection.

Each **cdma2000** carrier is likely to use unique options specified in IS-835 and may use proprietary solutions as well. As a result, the test system may need to be customized in order to simulate a specific carrier's implementation and should support field upgrades to accommodate this potential situation.

Simulator Requirements

Mobile IP requires many internet components in order to establish even a simple data call from a mobile device. As a result, debugging wireless devices is often limited to field testing where problems are fixed only as field engineers discover them. This method of validating a new product does not allow any consistent means of testing error conditions or conformance to standards. A controlled test system is essential if a product is expected to be reliable under less than ideal conditions.

A good lab test system should provide:

- a controlled environment
- consistent repeatable tests
- RF quality control
- call flow control
- handoff sequencing
- stable internet content
- Mobile IP network fault simulation
- test automation

Given these functions in a Mobile IP test system, the advantages of lab testing are obvious when compared to field testing that may exercise only a small fraction of the features and functions required by the Mobile IP standard.

MOB-IP-SIM Solution

The goal is to improve product verification beyond the limited scope of field testing. **MOB-IP-SIM** provides the test features needed to insure compliance with the IS-835 standard and simulates network error conditions as well.

System Overview

Fig. 5 shows the complete Mobile IP network test system configuration. Note that all the major components are consolidated into just two test blocks.

The first block, composed of an existing wireless test set or base station emulator, provides the required cdma2000 base station simulation and test control platform. This portion contains the radio link, call setup, and Inter-working Function (IWF) needed for packet data communications. System selection, call handoffs, call fades, and many other test scenarios can be configured using this system block.

The second block is SCI's **MOB-IP-SIM** that provides the additional functions needed to build a complete Mobile IP network simulation for a single wireless device. The unit interfaces to the base station emulator to provide the simulated **Foreign Agent (FA)** and **Home Agent (HA)** entities necessary to setup a wireless data connection.

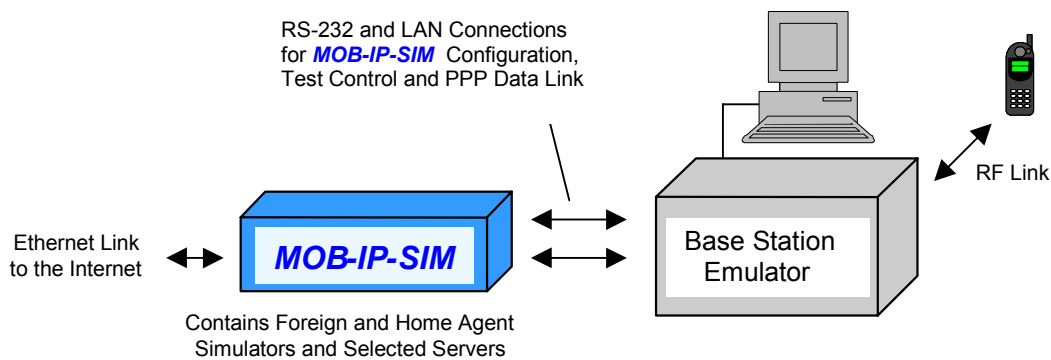

Fig. 5, Mobile IP Test System Using MOB-IP-SIM

By integrating the Base Station Emulator and the Mobile IP Simulator under a common test control environment, a powerful test platform is created to cover a wide range of test cases.

Hardware

The Mobile IP simulator is contained in a small enclosure with serial port and LAN connections. The box supports a single device and is designed to be paired with one of several supported base station emulator test sets. Either the serial port or LAN can be used to provide the PPP link needed to connect the mobile device through the base station emulator to the Mobile IP simulator network. The LAN connection also provides a Web based method of configuring the simulator to match your specific LAN requirements and allows connections to the internet as well as other entities such as a WAP Gateway or a real Home Agent.

Software

The Mobile IP simulator contains the components needed to setup an end-to-end data call complete with servers to provide built-in internet content.

The simulator contains the following software components:

- Foreign Agent and Home Agent simulator
- Configurable address translator for simulated web content to the device
- Data message and status logger
- PPP stack to connect the Mobile IP device
- Non-volatile configuration database
- Simple HTML test content
- FTP server with binary file for download test
- Customer defined test content
- HTTP proxy server for basic image format translations

Supported Features

MOB-IP-SIM supports many IS-835 related features and functions. This list represents the most significant areas of interest.

- **Reverse Link Tunneling** – User selectable option. Optional external Home Agent is allowed.
- **Authentication** - Automatic algorithm detection. User selectable failure modes.
- **Co-located Care-of Address** - User configurable option. Seldom used in live systems.
- **Agent Advertisement** - Conforms to IS-835 requirements. User configurable stress and failure modes.
- **Registration** - Conforms to IS-835 requirements. User configurable stress and failure modes.
- **PPP Negotiation** - Conforms to IS-835 requirements for both Mobile IP and Simple IP connections. User selectable failure mode.

Configuration

The simulator must be configured to work within the bounds of your local area network. This configuration sets up access to the external internet and provides routing connections to other entities that you plan to use as part of your wireless IP test environment. Setup is accessed through any standard internet browser connected to the LAN where the simulator is installed.

The simulator also provides dynamic configuration of several test parameters that can be controlled prior to each data connection attempt. These parameters are usually set directly by the test controller or test script in cases where test automation is implemented.

Test Automation

When combined with a base station emulator that supports script control, the MOB-IP-SIM Network Simulator becomes an integral part of the controlled test environment. Here are some examples of tests that can be performed with systems that support this level of test control:

1. Mobile IP call setup with user selectable Mobile IP fault tests during initial Mobile IP connection
2. Mobile IP call setup with user selectable Mobile IP fault tests after initial Mobile IP connection
3. Mobile IP Same PDSN soft handoff test during file transfer
4. Mobile IP PDSN to PDSN Hard Handoff test during file transfer
5. Mobile IP PDSN to PDSN using Fast Handoff during file transfer
6. Mobile IP Connected to Dormant/Idle to Connected State on same PDSN
7. Mobile IP Connected to Dormant/Idle to Connected State on new PDSN

Notes:

- Mobile IP logging results can be viewed using a standard web browser connected to the network.

Conclusion

MOB-IP-SIM provides an IS-835 compatible test solution that significantly enhances the product design, development, and testing of cdma2000 wireless devices. Standards continue to evolve and unique system deployments will create new challenges for designers. Software Concepts is able and committed to providing the needed test solutions for advances in IP mobility.

Looking beyond cdma2000 systems, Mobile IP continues to gain acceptance as the preferred solution for other wireless data devices because it can automatically span multiple protocols and air interfaces in order to provide continuous and optimal data connectivity. For example, Mobile IP could potentially be used to maintain a continuous data connection even as a mobile device moves from a cdma2000 network to a Wi-Fi network in a coffee shop, to your home networking system while maintaining a continuous connection to a streaming video session. As this type of seamless data service becomes available, Mobile IP simulators will become even more important in the area of product verification.